

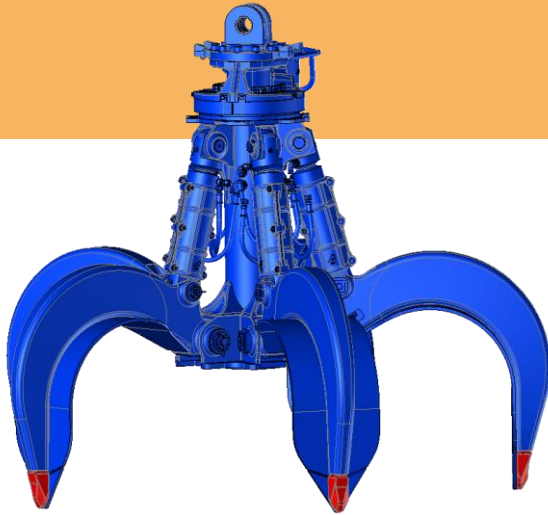

# G 951 – GA452 – GA550 G1851 – G7081



## Drapaky



- 1) Vnútrotný kardanový plášť.
- 2) Verzia : otočný kĺb alebo rotačný mechanizmus.
- 3) Kostra z HLE ocele.  
Vnútrotná rúrková sústava.  
Ochranný kryt valcov.
- 4) Valce s chráničmi tyčí.
- 5) Hriadele s vysokofrekvenčnou tepelnou úpravou.
- 6) 3, 4 alebo 5 drapakov.
- 7) Konštrukcia s prečnievajúcim plechom z ocele odolnej voči oderu.
- 8) Odnímateľné súčiastky najviac vystavené opotrebeniu.

**Varianty :** vertikálne ½ uzavreté (a)  
horizontálne ½ uzavreté (b)  
úplne uzavreté (c)

Verzia na kamene (d) : od GA452

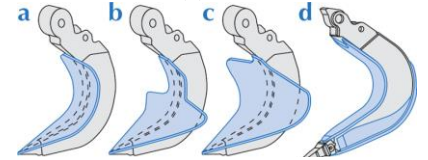

Min. Max. Ø A B ØC ØD E F



	t	t	l	Min. Kg	Max. Kg	Ø mm	A mm	B mm	ØC mm	ØD mm	E mm	F mm	bar	l/mn	bar	l/mn	t
<b>G 951</b>	9	9	360	700	855	1750	1620	1325	1342	1916	430	1430	320	45/95	320	7/10	11/15
<b>GA452</b>	15	15	400	1260	1470	1800	2072	1770	1425	2090	456	1510	350	70/140	140	15/20	20 / 24
<b>GA452</b>	15	15	600	1310	1570	2000	2183	1815	1534	2300	503	1660	350	70/140	140	15/20	20 / 24
<b>GA550</b>	15	15	800	1395	1735	2200	2260	1870	1620	2500	545	1865	350	95/190	140	15/20	24/27
<b>GA550</b>	15	15	1000	1445	1890	2400	2370	1920	1780	2735	590	2030	350	95/190	140	15/20	24/27
<b>GA550</b>	-	20	800	1555	1895	2200	2440	2050	1620	2500	545	1865	350	95/190	140	15/20	28/31
<b>GA550</b>	-	20	1000	1605	2050	2400	2550	2100	1780	2735	590	2030	350	95/190	140	15/20	28/31
<b>G1851</b>	-	25	780	2550	3055	2400	2630	2285	1770	2700	700	2080	350	145/285	140	20/25	31/45
<b>G1851</b>	-	25	1075	2950	3455	2800	2880	2410	1860	3140	830	2320	350	145/285	140	20/25	31/45
<b>G1851</b>	-	25	1500	3040	3610	3000	2993	2470	1968	3340	879	2461	350	145/285	140	20/25	31/45
<b>G7081</b>	-	25	2200	3470	4190	3200	3100	2540	2270	3570	780	2650	350	240/480	140	20/25	46/53

Hmotnosti sú uvádzané bez odpruženia kardanu pre 5 drapakové verzie.

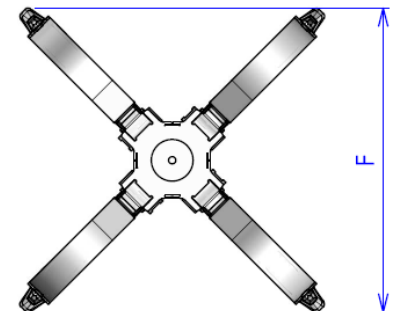
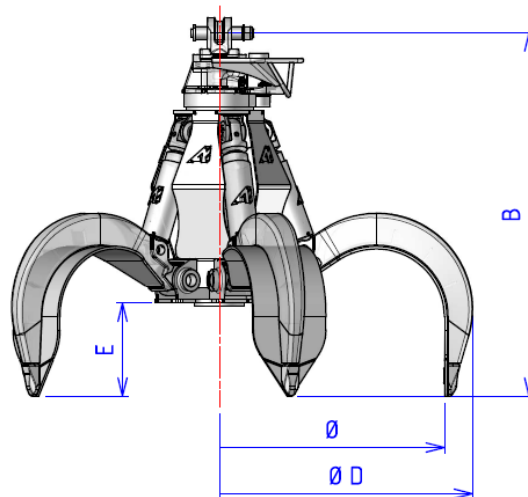
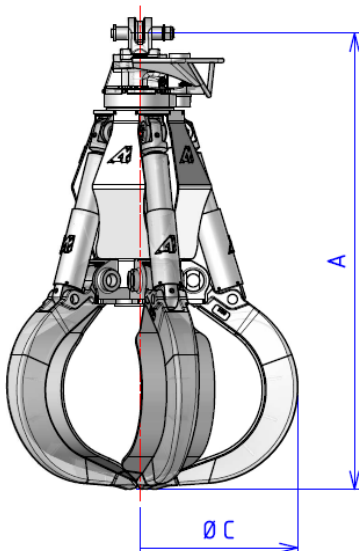

Hlavné rozmery 4- drapakovej verzie